



Instructions for Use

Membrane Oxygenator
OxyPrime DUO

SUMMARY

1. DESCRIPTION.....	3
1.1. GRAPHIC IMAGES	4
1.2. TECHNICAL SPECIFICATIONS	5
2. PRESENTATION.....	6
3. INTENDED PURPOSE	6
4. INDICATION FOR USE	6
5. CONTRAINDICATIONS.....	6
6. CLINICAL BENEFITS.....	6
7. ADVERSE EFFECTS.....	6
8. INSTRUCTION FOR USE.....	7
8.1 SET-UP.....	7
8.2 ASSEMBLY OF BLOODLINES	7
8.3 ASSEMBLY OF GAS AND WATER LINES	8
8.4 PRIMING PROCEDURE	9
8.5 PERFUSION CONTROL.....	9
8.6 EMERGENCY OXYGENATOR REPLACEMENT.....	10
8.7 COMMON PROBLEMS AND POSSIBLE SOLUTIONS	10
9. WARNINGS	11
10. PRECAUTIONS	12
11. STORAGE AND TRANSPORT.....	13
12. PRODUCT DISPOSAL	13
12.1 SAFE DISPOSAL PROCEDURE.....	14
13. PERFORMANCE DATA	15
14. SHELF-LIFE	16
15. WARRANTY	16
16. MANUFACTOR INFORMATION	17
17. SYMBOLS DESCRIPTION	18
18. LABEL TEMPLATE.....	19

READ INSTRUCTIONS BEFORE USE

Model: Membrane Oxygenator Oxyprime DUO (code 618949)

1. DESCRIPTION

The Membrane Oxygenator Oxyprime DUO consists of two coupled chambers (Gas Exchanger and Heat Exchanger), being indicated for procedures lasting up to 6 hours.

The internal space of the gas exchanger is filled with a hydrophobic Polypropylene (PP) membrane, formed by capillaries (fibers) with a highly porous surface. The high porosity of the capillaries, associated with a uniform distribution of pores, provides the membrane with high gas transfer (diffusion) performance, desirable to meet the fundamental principle of an oxygenator: efficiency in transferring O₂ to the blood and in removing carbon dioxide (CO₂).

The Membrane Oxygenator Oxyprime DUO has an integrated blood filter, made of polyester, developed especially for this application. The filter has an opening of 41 microns, the hydrophobic characteristics of the fabric make it difficult for air bubbles to pass through and filtering particles and clots larger than its opening. In addition to the arterial filter, the Membrane Oxygenator Oxyprime DUO has an air bubble removal geometry in the heat exchanger part, in which the extension tube must be connected to the heat exchanger's luer connector (called Bubble Trap). This geometry is responsible for eliminating large embolisms that may enter the circuit, and must remain open during the procedure.

The internal space of the heat exchanger is filled with thermoplastic polymer (polyester) capillaries. This thermoplastic composition, combined with the characteristics of the production process, results in non-porous capillaries, totally impermeable to blood and water, and with a high thermal transfer capacity.

All the Oxygenator surfaces in contact with the blood are treated with the biocompatible coating, named BRCoating, composed of water produced by reverse osmosis, Polyethylene glycol 300 and recombinant human albumin*. This solution coats the inner surface of the product, reducing the interaction of the blood with it.

*Recombinant human albumin it is not derived from Animal or Human sources.

1.1. Graphic images

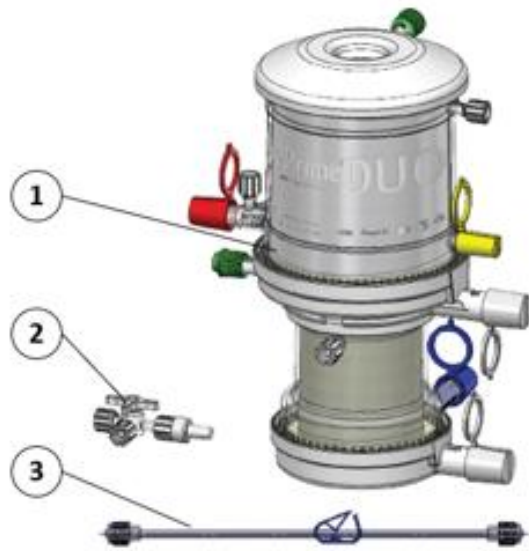

1. Membrane Oxygenator
2. Three way stop-cock
3. Extension Tube

Figure 1 - Membrane Oxygenator Oxyprime Duo

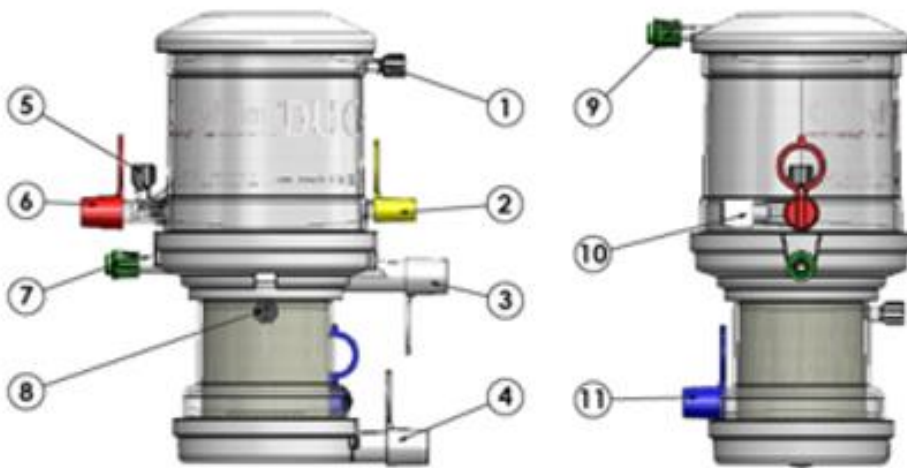

1. Air Removal
2. Recirculation
3. Water inlet
4. Water Outlet
5. Arterial Sample
6. Arterial Blood Outlet
7. Gas Outlet
8. Bubble Trap
9. Gas Inlet
10. Temperature Sensor
11. Venous Blood Inlet

Figure 2 - Detailing the parts of the product

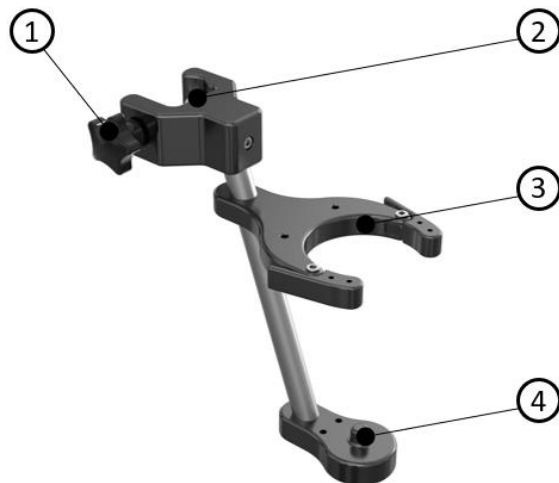

1. Knob
2. Support Clamp
3. Support Claw
4. Base Fitting

Figure 3 - Dedicated Support (Holder) – Sold Separately

1.2. Technical Specifications

Table 1 - Technical Specifications

MATERIAL	
Housing/connector Material	Polycarbonate
Protective covers	Polyethylene
Coating	BRCoating
PERFORMANCE	
Maximum Blood flow rate	7.0 L/min
Blood inlet maximum pressure	100 kPa (760 mmHg)
Priming volume (Static)	270ml
Particle filtration efficiency	98.3 ± 1%
Air handling capability	99.0% or more
Gas flow: blood flow ratio	0.5:1 - 1:1 - 2:1
GAS EXCHANGER	
Fiber Material	Polypropylene
Surface Area	2.0 m ²
Temperature connector	YSI
ARTERIAL FILTER	
Arterial Filter	Polyester Fabric
Surface Area	500cm ²
Porous Size	41 microns
HEAT EXCHANGER	
Fiber material	Polyester
Surface Area	0.40 m ²
Water Maximum temperature	42°C
Water maximum pressure	32 PSI (1660 mmHg)
CONNECTORS	
Blood inlet	3/8" (9.5 mm)
Blood outlet <i>Direction: Right Side</i>	3/8" (9.5 mm)
Gas inlet	1/4" (6.4 mm)
Recirculation	1/4" (6.4 mm)
Bubble-trap connector	Luer lock
Water connector	1/2" (12.7 mm) Hansen quick connect fittings
Temperature connector	YSI
Arterial Sample connector	Luer lock
Air Removal connector	Luer lock

Disclosable information: Information on blood cell damage, data tolerances and leaching. If during the use of this device or as a result of its use, a serious incident has occurred, please report it to the manufacturer and/or its authorized representative and to

your national authority.

2. PRESENTATION

The Membrane Oxygenator Oxyprime DUO is sterile (sterilized by Ethylene Oxide - ETO) and non-pyrogenic. In its primary packaging, the product is packed in Tyvek paper envelope and polyethylene film. In its secondary packaging, the Membrane Oxygenator Oxyprime DUO is packed in a cardboard box. The instruction manual accompanies the product, in the secondary packaging.

3. INTENDED PURPOSE

The Membrane Oxygenator Oxyprime Duo is intended to be used in an extracorporeal perfusion circuit to oxygenate and remove carbon dioxide from the blood, to cool or warm the blood, and to filter gaseous micro emboli and particles larger than the specified micron size during cardiopulmonary bypass (CPB) procedures up to 6 hours in duration.

4. INDICATION FOR USE

The Membrane Oxygenator Oxyprime Duo is intended to be used for patients who need surgical procedures requiring cardiopulmonary bypass (CPB).

The Membrane Oxygenator Oxyprime Duo is for use with patients when required blood flow rate (cardiac output) will not exceed 7L/min.

This device shall only be used by properly trained and qualified personnel.

5. CONTRAINDICATIONS

This device is contraindicated to perform other functions that are not determined by the indication for use, or even when, in the opinion of the medical team, its use is contrary to the best benefits for the patient.

6. CLINICAL BENEFITS

Enabling surgical procedures that require cardiopulmonary bypass by using blood circuits including this device.

7. ADVERSE EFFECTS

Use of this medical device may cause: Pressure drop, Hemolysis, Blood Loss, Inflammatory reaction, Embolism, Hypoxia, Infection Organ and tissue failure; Septic Shock, Kidney Failure, Heart attack, cell death, Permanent damage; Death.

8. INSTRUCTION FOR USE

It is recommended to use the Braile Biomédica Membrane Oxygenator OXYPRIME Duo with devices from the Braile Biomédica brand, listed in Table 2.

Description	Code
Tubing Set Adult BRCoating	622286
Blood Reservoir Venous 4000 BRCoating	622258
Blood Reservoir Cardiotomy 4000 BRCoating	622272
Centrifugal Pump Safira Centriflux with BRCoating	616322
Support for Oxyprime oxygenator	610149

Table 2 - Compatible devices (sold separately)

* Braile Biomédica cannot guarantee the compatibility between products from other manufacturers and, consequently, their safety and effectiveness.

8.1 Set-Up

- a. **Support (Holder):** Turn the knob counterclockwise to free the support Fixing clamp (item 2 of Figure 2) and be able to position it on the rod freely. Set the holder at the appropriate height to prevent the lines from kinking, and turn the handle clockwise to fix the support. The oxygenator support must always be fixed below the blood venous reservoir support;
- b. **Oxygenator:** Open the sterile packaging using aseptic techniques.
- c. Remove the oxygenator and attach it to its support, by fit the hole in the oxygenator base into the support base fitting. Subsequently, fit the upper part of the oxygenator (gas exchanger) into the movable claws of the support, make sure that the oxygenator is well fixed and secure in the support.

8.2 Assembly of Bloodlines

Note 1: Consult the instruction manuals for the Tubing Set and the Venous Reservoir before starting the circuit assembly.

Note 2: The Venous Reservoir must always be positioned above the Oxygenator.

- a. Connect the cava (venous) line (1) of the Tubing Set to the venous inlet connector (2) of the Venous Reservoir and clamp it;
- b. Connect the recirculation line (3) to the Oxygenator and Venous Reservoir recirculation connectors and clamp it;

- c. Connect the pump line (4) to the blood outlet connector of the Venous Reservoir and to the blood inlet connector of the Oxygenator heat exchanger and clamp it;
- d. Connect the arterial line (5) to the Oxygenator blood outlet connector and clamp it;
- e. To assemble the air removal line: connect the product's three-way stop cock to the air removal luer connector of the heat exchanger and, later, connect the product's extension tube to the three-way stop cock and to the Venous Reservoir. This line must always be kept open to avoid embolism;
- f. Check all connections and, for safety, secure them with the clamps that come with the Tube Set.

8.3 Assembly of Gas and Water Lines

- a. Connect the Gas Mixer/Flowmeter output (7) to the Gas Filter. Consult the Gas Mixer/Flowmeter instruction manual before use and utilize the manufacturer's recommended gas inlet pressures;
- b. Connect the gas line (8) to the Gas Filter and to the Oxygenator gas inlet connector. Make sure the Oxygenator gas outlet is unobstructed;
- c. Connect the Water Circulator to the water inlet/outlet connectors (9) of the Oxygenator heat exchanger. Consult the instruction manual for the Water Circulator module before starting the circuit assembly.
- d. Connect the bubble-bubble trap line (10) of the heat exchanger in the luer connector of the Blood Reservoir Venous.

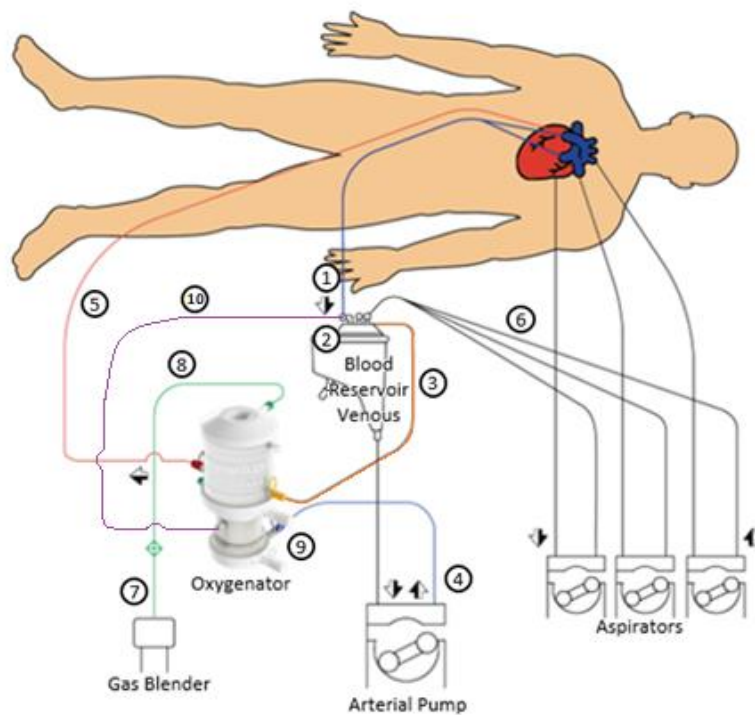

Figure 4 - CPB circuit assembly diagram

8.4 Priming Procedure

- a. Clamp the pump line and the arterial blood outlet of the Oxygenator. Leave the recirculation line and pump line not clamped;
- b. Introduce the priming solution through the Venous Reservoir cap connectors intended for drug delivery, so that the solution passes through the reservoir filter;
- c. circulate the priming solution until the air bubbles in the Oxygenator are completely eliminated;
- d. Open the clamp in the arterial line and clamp the recirculation line, then increase the rotation in arterial pump up to 7,0L/min, make sure that all devices and tubes in the CPB circuit are free of air bubbles and leak points;

Note 3: The adjustment of the occlusion of the Arterial Pump rollers must be performed prior to the assembly of the CEC circuit, according to the instructions contained in the Pump's instruction manual.

- e. Stop the arterial pump, clamp the arterial line and the venous line;
- f. To start cardiopulmonary bypass, connect venous line and arterial line to the venous and arterial cannulas, respectively, making sure there are no air bubbles at the connection points, and adjust the perfusion parameters according to the team's standard protocol. surgical.

8.5 Perfusion Control

Oxygenation and CO₂ removal controls during perfusion are independent. By varying the gradients of partial pressure of oxygen (pO₂) and partial pressure of carbon dioxide (pCO₂) between blood and gas mixture, oxygenation and CO₂ removal are altered, respectively.

To change (increase or decrease) the blood oxygenation level, the oxygen concentration (FiO₂) in the Gas Mixer must be varied. To change (increase or decrease) the carbon dioxide removal capacity, you must vary the flow of the gas mixture in the Oxygenator, that is, change the gas flow/blood flow ratio.

Blood temperature is controlled by regulating the temperature of the water that circulates through the Oxygenator heat exchanger.

Note 4: The connection for the Temperature Sensor (item 10 of Figure 2) is the place destined for the coupling of a Temperature Sensor, whose purpose is to monitor the blood in the arterial outlet.

8.6 Emergency Oxygenator Replacement

In case of failures or leaks in the Oxygenator, the procedure below must be followed to replace the unit:

- a. Remove the reserve Oxygenator from the packaging and check its integrity;
- b. Clamp the arterial and venous lines;
- c. Stop rotation and water flow in the heart-lung machine;
- d. Close gas flow;
- e. Place tube clamps close to the oxygenator blood outlet and blood inlet connectors, close the recirculation line;
- f. Remove the oxygenator to be replaced from the holder and replace with the new one;
- g. Remove the arterial line from the oxygenator to be replaced and connect it to the new one;
- h. Remove the venous line from the oxygenator to be replaced and connect to the new one;
- i. Remove the pump line from the oxygenator to be replaced and connect to the new one;
- j. Place the recirculation line in the new oxygenator and keep it open;
- k. Open the clamp next to the blood inlet connector and allow the solution to flow until it is completely filled, through the prime inlet connector;
- l. Do the step describe in 8.4;
- m. Make sure there are no bubbles in the circuit;
- n. Remove all other clamps (venous, arterial and water lines);
- o. Turn on the pump, the gas flow and the water circulator and restart the perfusion;

8.7 Common Problems and Possible Solutions

Table 3 - Common Problems and solutions

Problems and solutions	
low pO ₂	Increase O ₂ %
high pO ₂	Reduce O ₂ %
low pCO ₂	Decrease gas flow
high pCO ₂	Increase gas flow

9. WARNINGS

- Read the instructions before use;
- Single use product. Therefore, do not re-sterilize or reuse the product. There are no data to support the sterility, pyrogenicity and functionality of devices after reprocessing;
- Reprocessing prohibited. Reprocessing may compromise the sterility, biocompatibility and functional integrity of the device (leaks, low performance, membrane rupture and filter failure);
- Do not use non-sterile products - they must be sterile before use;
- Do not use the product after the expiry date;
- Do not use the product if it is damaged or the packaging is broken;
- Before use, the product must be checked for proper operation and to ensure the model is suitable for its intended purpose;
- Product intended exclusively for medical use;
- The product should only be used by people specially trained on cardiopulmonary bypass (CPB) techniques;
- The procedure and the correct application of the product are the responsibility of the doctor who performs the treatment;
- The product must not be used under conditions that contradict its technical specifications, under penalty of loss of performance or accidents. It is up to the person responsible for using the product to check in advance whether the technical specifications meet the needs of the procedure to be performed;
- Always use aseptic techniques when handling the product after opening;
- Avoid any impacts during transport or use;
- Do not use the product in case of doubt;
- The product should be used immediately after opening the package. After use, dispose of safely as medical waste according to health institution policies. The product is biohazardous as it is contaminated with blood;
- Pressure at the blood inlet of the oxygenator should not exceed 100kPa (760 mmHg). Pressure greater than 100kPa may cause leaks or damage to the device;
- Water pressure at the heat exchanger inlet should not exceed 220kPa (1660mmHg). Pressure greater than 220kPa may cause leaks or damage to the device;
- When using the centrifugal pump on the arterial line, clamp the arterial line distal to the oxygenator (the patient's side) before stopping the pump. Improper clamping may cause back-flow or migration of gaseous emboli into the blood side;

10. PRECAUTIONS

- It is recommended that you check the product carefully before use. The operation of the product packaging may be affected by transport. It is not possible to guarantee full operation of the product when transport damage occurs. If the product has been dropped or crushed, it cannot be used and must be replaced with a new product;
- Always keep a spare unit of the product during the procedure;
- The manufacturer is not responsible for damage resulting from lack of experience, misuse or failure to follow the instructions for use;
- During the procedure, blood anticoagulation protocol should be adopted;
- Protamine should not be used in patients before or during extracorporeal circulation;
- It is necessary to provide correct heparinization and accurate monitoring of the anticoagulation status before, during or after extracorporeal circulation;
- Check all circuit connections in advance to prevent any leaks;
- Remove all air from the extracorporeal circuit before the start of CPB using the circuit prime procedure;
- It is recommended to start the procedure immediately after filling with prime in order to minimize the period of microbiological contamination, precipitation of the filling solution;
- Do not make changes to the product;
- Do not use the product if not all connectors are protected with a protective cover. The protective covers must be retained immediately before use;
- Regularly monitor the patient to identify side effects of cardiopulmonary bypass (e.g., infections, hemolysis, post-perfusion syndrome and organ damage);
- Regularly monitor the patient clotting status (e.g., activated clotting time and partial thromboplastin time). The anticoagulation control protocol is the responsibility of the responsible user;
- Broken and / or leaking connectors must be replaced;
- Tube metal clamps should be available;
- During transport of patient, avoid leaving the tubes hanging, excessive forces, bumps and kinks;
- To collect samples, avoid creating bubbles in the circuit;
- Monitor collection and recirculation lines to prevent clots;
- To ensure optimal operation of the oxygenator, additional devices or connections are required. Read the instructions for use carefully before using the device, ensuring that all necessary parts are available before use;
- Avoid bumping into the oxygenator during the prime procedure;

- During infusion, the blood pressure in the oxygenator gas exchanger must always be kept higher than the gas pressure to prevent formation of micro-bubbles in blood (gas embolism);
- The gas outlets of the oxygenator must never be blocked, as this causes an increase in gas pressure in the gas exchanger, which can cause gas embolism;
- The maximum blood flow of the oxygenator model used must not be exceeded;
- Blood flow should never be reduced suddenly. The sudden reduction or sudden stop of blood flow causes a decrease in blood pressure in the gas exchanger, which can cause gas embolism. The reduction or stop of blood flow must always be done gradually and accompanied by reduction in gas flow, with continuous monitoring of gas and blood pressures in the gas exchanger;
- Whenever the Arterial Pump is stopped (zero flow), the gas flow must be closed (zero flow), under the risk of gas embolism;
- Monitor oxygenation and carbon dioxide removal throughout the procedure through periodic gas analysis;
- Monitor the suction pressure in the venous line, check if luer connections and 3-way valves are closed to avoid embolism in the line;
- Monitor oxygenator pressure gradient (pressure before and after the oxygenator);
- Monitor gas exchange performance in gas analysis;
- Always position the oxygenator below the patient level;
- Never infuse drugs directly into the oxygenator connectors;
- Do not use solvents such as alcohol, ether, acetone, liquid anesthetics by inhalation (for example: Halothane, Enflurane, etc.), as these can damage the product;
- In case of need to replace the Oxygenator during procedure, proceed according to related instructions contained in the Product Replacement Instructions.

11. STORAGE AND TRANSPORT

The product in its original packaging must be stored in a clean, dry, weather-free environment and at temperatures above -10°C and below 40°C. For its transportation, it should never be refrigerated, frozen or exposed to temperatures above 40°C.

12. PRODUCT DISPOSAL

After use, follow the **safe disposal procedure, item 12.1**, to safely dispose of the device. Product and packaging disposal must comply with the hospital and / or local

government policy. The product must be disposed of only in hospital / infectious waste. The product is biohazardous as it is contaminated with blood.

12.1 Safe Disposal Procedure

Warning: Wear gloves to carry out this process, there is a risk of contamination.

Note 5: It is not necessary to disconnect the bloodlines tubes.

Note 6: This safe disposal procedure serves the cardiopulmonary bypass circuit and its main components (Tubing Set, Oxygenator, Blood Reservoir Venous/Cardiotomy and centrifugal pump). For specific components, follow instructions that come with the device in question.

- a. Remove the aspirators lines from the roller of the heart-lung machine and set them aside on a secure surface.
- b. Remove the pump line from the roller of the heart-lung machine or, if using a centrifugal pump, detach it and set aside on a secure surface.
- c. Position a surgical field below the oxygenator to avoid wetting the floor, clamp the water lines near the oxygenator's water inlet/outlet connectors, and, disconnect the lines, set the pipes aside on a safe surface.

Note 7: For the next steps, use the disposal waste for contaminated products.

Note 8: Always handle the Venous Reservoir and the Cardiotomy Reservoir in an upright position to avoid blood overflow through the top cover.

- d. Remove the oxygenator and venous reservoir from their respective holders and discard it carefully.
- e. Remove the Cardiotomy reservoir from the holder and discard it carefully.
- f. Discard the remaining lines, including the centrifugal pump line if used.

13. PERFORMANCE DATA

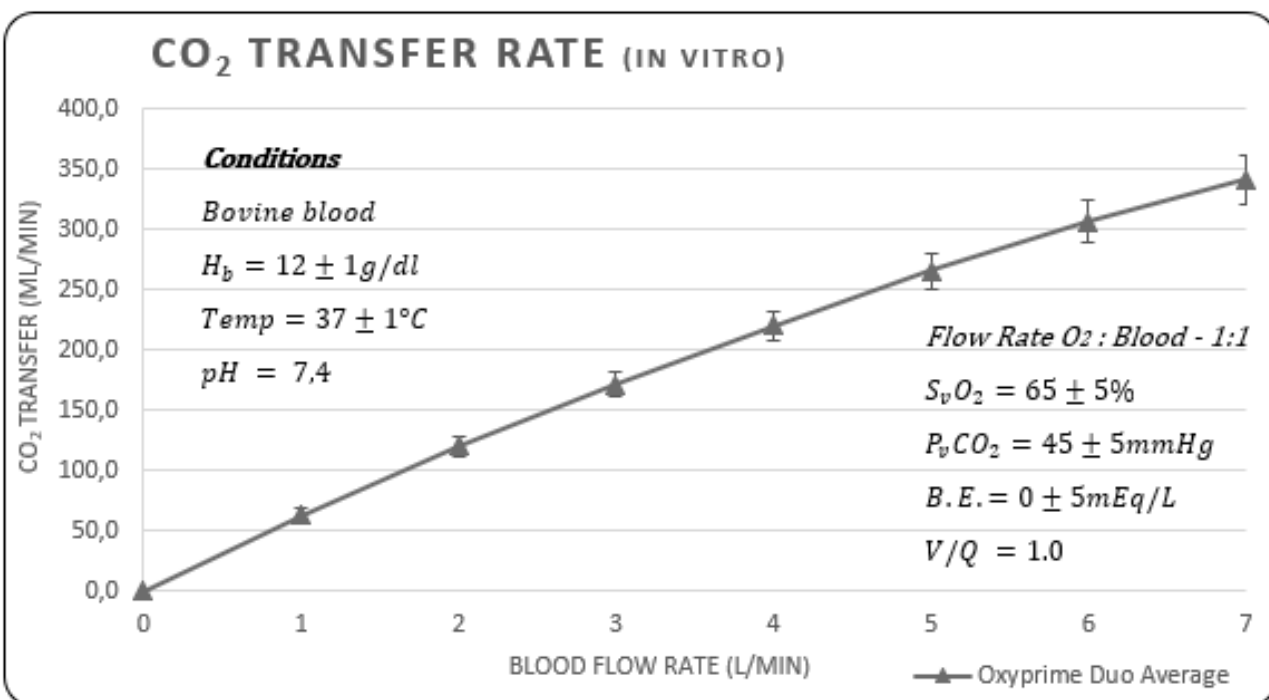
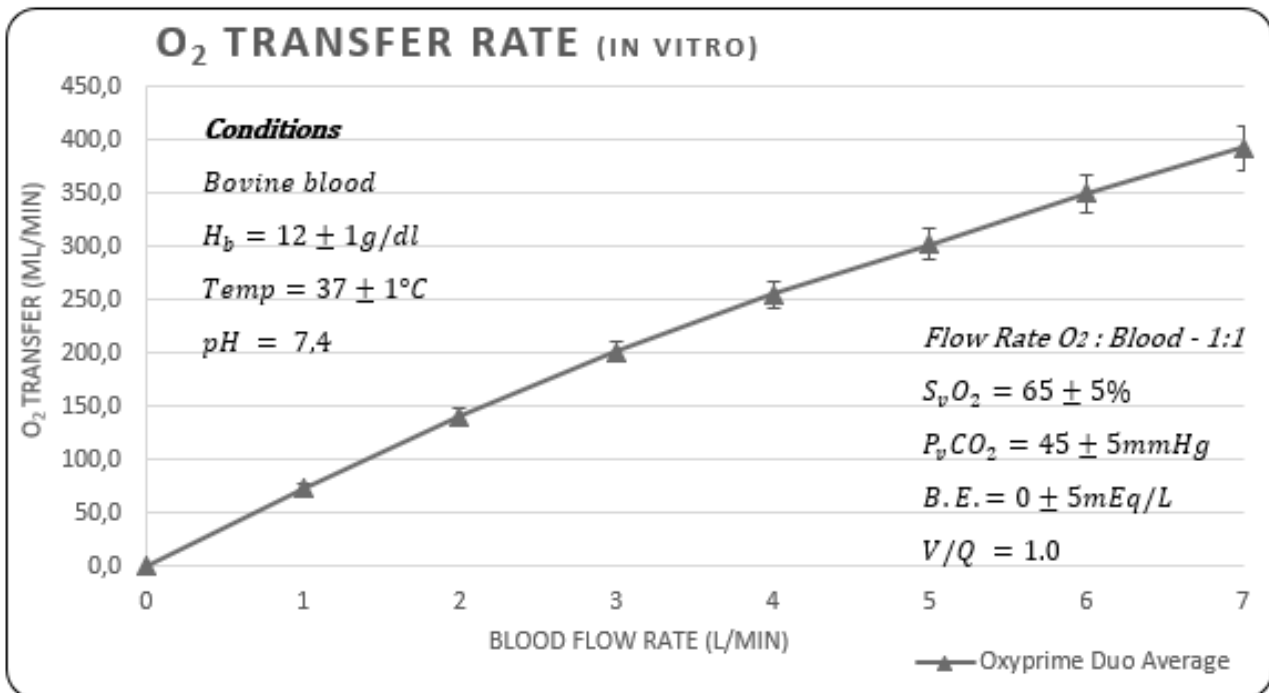

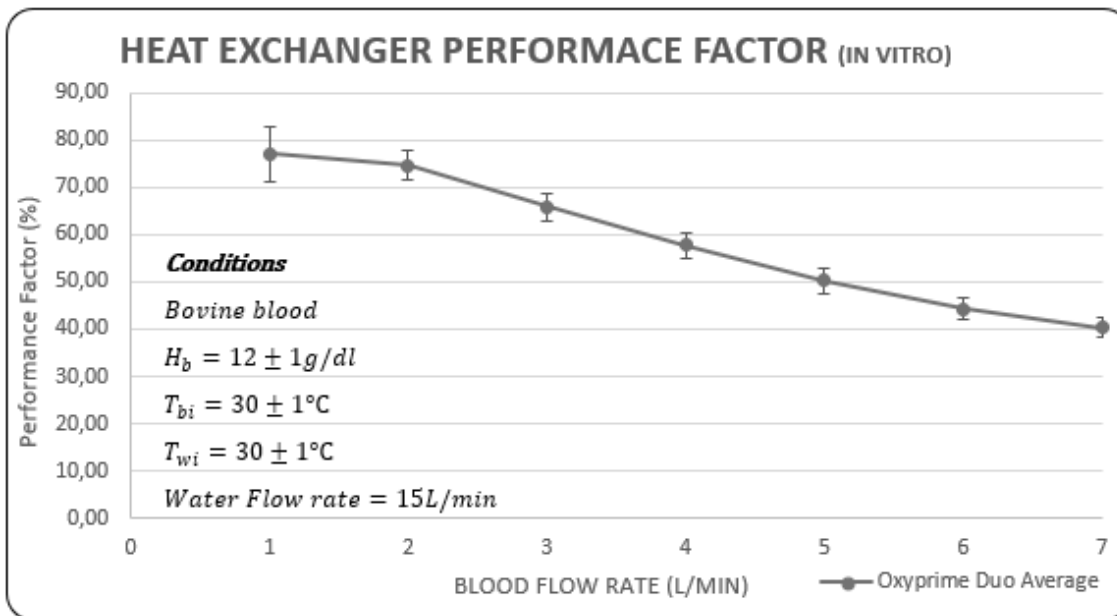
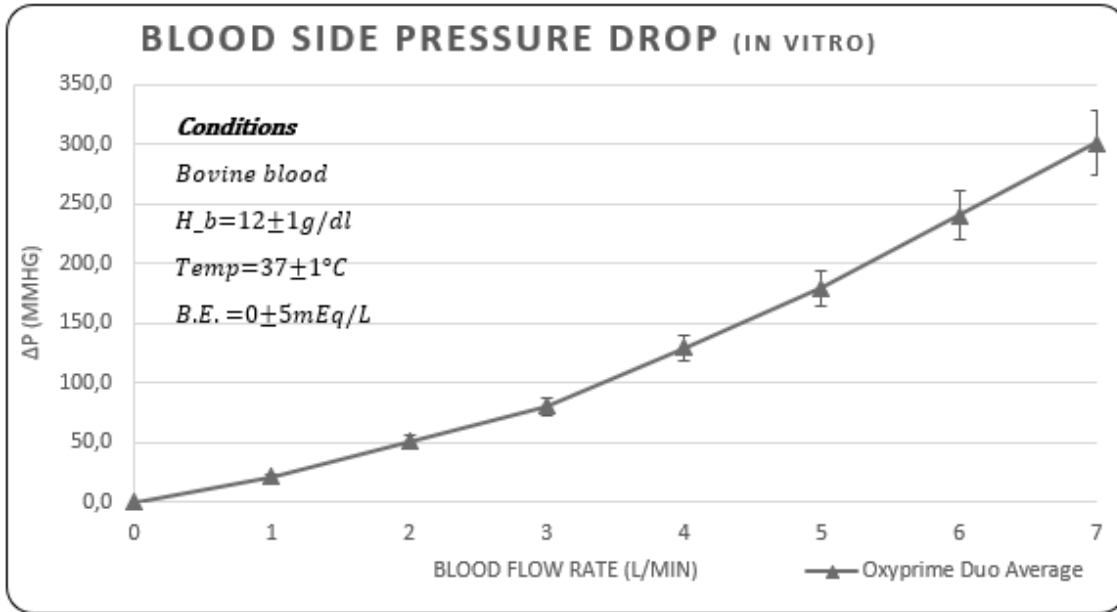

14. SHELF-LIFE

The Membrane Oxygenator Oxyprime DUO is valid for 1 year after the sterilization date, considered sterile only if the package has not been violated. Check the validity date on the label of the product package.

15. WARRANTY

Braile Biomédica Indústria, Comércio e Representações Ltda, certifies that the product has been manufactured with due care, with good quality materials, and is warranted for manufacturing defects pursuant to the Brazilian Consumer Protection

Code. It further clarifies that if the product is violated by unauthorized or unqualified personnel, the warranty will be void. The manufacturer states that any other warranty expressly or implicitly granted by others shall not be valid. The use of the product is restricted to doctors or qualified and trained technicians under the supervision of the responsible physician, who are familiar with the procedures for using the product, being their responsibility said use. The manufacturer will not be responsible for any damage resulting from product misuse.

Braile Biomédica Ltda also states that the right to complain about the product will be governed by the provisions contained in Article 26 of the Brazilian Consumer Protection Code (Law 8.078 / 90). No agent, employee, representative, or distributor of the Braile Biomédica Ltda has the authority to change or amend what is described herein, assume or bind the Braile Biomédica Ltda to any other liability or warranty in connection with this product.

This product was developed and manufactured based on legal and regulatory requirements, and under strict quality control, aiming at managing potential risks of its use, in order to minimize them within safe limits. However, Braile Biomédica cannot ensure that the product is totally free from the likelihood of failure, so that its use must respect all precautions, restrictions, warnings, special care and relative instructions for use, as well as must be constantly and carefully monitored.

16. MANUFACTOR INFORMATION

Manufactured by:

Braile Biomédica Indústria Comércio e Representações Ltda

CNPJ N°: 52.828.936/0001-09

Av. Presidente Juscelino Kubitschek de Oliveira, 1505 – Jardim Tarraf I

CEP: 15091-450

São José do Rio Preto – São Paulo

Imported and distributed by:

Mars Medical























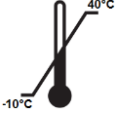

Landhausstrasse 46

70190, Stuttgart – Germany

Tel: +49 1751938653

E-Mail: info@marsmedical.de

17. SYMBOLS DESCRIPTION

	Manufacturer		Use-by date
	Catalog Number		Sterile
	Serial Number		Sterilized using ethylene oxide
	Batch Code		Do not use if packaging is damaged
	Date/ Country Manufacture		Fragile, handle with care
	Non-pyrogenic		This way up
	Consult Instructions for Use or electronic instructions for use		Stacking limit
	Temperature limit		Recyclable
	Keep dry		Medical Device
	Keep away from sunlight		Do not re-use
	Unique Device Identifier		Do not resterilize
	CE Mark		Authorized representative in the European Union

18. LABEL TEMPLATE

	<p>Braile Biomédica Indústria Comércio e Representações Ltda. Av. Presidente Juscelino Kubitschek de Oliveira, 1505 - Jardim Tarraf I CEP 15091-450 - São José do Rio Preto - SP - Brasil Fone: +55 17 2136-7000 SAC: 0800 707 20 50 CNPJ: 52.828.936/0001-09 www.braile.com.br</p>							
<table border="1" style="border-collapse: collapse;"> <tr> <td style="padding: 2px 5px;">EC</td> <td style="padding: 2px 5px;">REP</td> </tr> </table>	EC	REP	<p>Mars Medical Landhausstrasse 46 70190, Stuttgart – Germany Tel: +49 1751938653 E-Mail: info@marsmedical.de</p>					
EC	REP							
<h3>MEMBRANE OXYGENATOR OXYPRIME DUO</h3>								
<p>Description (Model): 618949 Package Content: 01 unit of Membrane Oxygenator Oxyprime Duo / 01 Instruction for Use Contains 1 unit destined to medical application</p>								
<p>ANVISA Registration nº: XXXXX Technical Name: Oxygenator Technician in Charge: Vladimir D. A. Ramirez – CRF-SP 09010</p>								
<p>Read instructions before use Single use product / Prohibited reprocessing</p> <p>Indications, Precautions, Warnings, Instructions of Use, Preservation Cares*. * Please refer to leaflet insert "INSTRUCTIONS OF USE".</p>								
<table border="1" style="border-collapse: collapse;"> <tr> <td style="padding: 2px 5px;">REF</td> <td style="padding: 2px 5px;">XXXXXX</td> </tr> </table>	REF	XXXXXX	<table border="1" style="border-collapse: collapse;"> <tr> <td style="padding: 2px 5px;">SN</td> <td style="padding: 2px 5px;">XXXXXX</td> </tr> </table>	SN	XXXXXX	<table border="1" style="border-collapse: collapse;"> <tr> <td style="padding: 2px 5px;">LOT</td> <td style="padding: 2px 5px;">XXXXXX</td> </tr> </table>	LOT	XXXXXX
REF	XXXXXX							
SN	XXXXXX							
LOT	XXXXXX							
<table border="1" style="border-collapse: collapse;"> <tr> <td style="padding: 2px 5px;">  </td> <td style="padding: 2px 5px;">YYYY/MM/DD</td> </tr> </table>		YYYY/MM/DD	<table border="1" style="border-collapse: collapse;"> <tr> <td style="padding: 2px 5px;">UDI</td> </tr> </table>	UDI				
	YYYY/MM/DD							
UDI								
<table border="1" style="border-collapse: collapse;"> <tr> <td style="padding: 2px 5px;">  </td> <td style="padding: 2px 5px;">YYYY/MM/DD</td> </tr> </table>		YYYY/MM/DD						
	YYYY/MM/DD							
<table border="1" style="border-collapse: collapse;"> <tr> <td style="padding: 2px 5px;">STERILE</td> </tr> </table>	STERILE	<table border="1" style="border-collapse: collapse;"> <tr> <td style="padding: 2px 5px;">STERILE EO</td> </tr> </table>	STERILE EO					
STERILE								
STERILE EO								
			<table border="1" style="border-collapse: collapse;"> <tr> <td style="padding: 2px 5px;">MD</td> </tr> </table>	MD	<p>braile.com.br/en/produutos/cemark/products</p>			
MD								

The external package has the following informations

The product must be stored and transported in its original packaging, in a clean, dry, weather-free environment and at a controlled temperature.

