



Instructions for Use

Centrifugal Pump

Safira Centriflux

with BRCoating



Content

1	PRODUCT DESCRIPTION.....	3
1.1	Graphic Images.....	3
1.2	Technical Specifications.....	4
2	PRESENTATION	6
3	INTENDED PURPOSE	6
4	INDICATION FOR USE.....	6
5	CONTRAINDICATIONS	7
6	CLINICAL BENEFITS.....	7
7	ADVERSE EFFECTS.....	7
8	INSTRUCTION FOR USE.....	7
8.1	Circuit Assembly	7
8.2	Filling with Prime for ECLS.....	8
8.3	Filling with Prime for Cardiac Surgery	8
8.4	Start of infusion	9
8.5	Perfusion Control	9
8.6	End of Perfusion	9
8.7	Replacing the Centrifugal Pump.....	9
9	WARNINGS AND PRECAUTIONS	10
10	STORAGE AND TRANSPORT.....	13
11	PRODUCT DISPOSAL	13
11.1	Safe Disposal Procedure	13
12	PERFORMANCE DATA	14
13	SHELF-LIFE	14
14	WARRANTY	14
15	MANUFACTOR INFORMATION.....	15
16	SYMBOLS DESCRIPTION	16
17	LABEL TEMPLATE.....	17

READ INSTRUCTIONS BEFORE USE

Model: Centrifugal Pump Safira Centriflux with BRCoating (code 616322)

1 PRODUCT DESCRIPTION

The Centrifugal Pump Safira Centriflux with BRCoating consists of a body (housing) with two connectors (upper inlet and lateral outlet of blood), which contains a rotor (by magnetic coupling), responsible for generating the centrifugal force that drives the blood. The product is composed of polymeric materials and a sphere suitable for medical applications and sterilizable by Ethylene Oxide (ETO).

The body and internal rotor of the Centrifugal Pump, components with greater contact with blood, are made of polycarbonate (PC) injected with a profile that allows a reduction in hemolytic traumas normally associated with ECMO procedures; the magnet is N48 Bipolar and the protective covers are made of Polyethylene. In addition, all the device surfaces in contact with the blood are treated with the biocompatible coating, named BRCoating, composed of water produced by reverse osmosis, Polyethylene glycol 300 and recombinant human albumin*. This solution coats the inner surface of the product, reducing the interaction of the blood with it.

*Recombinant human albumin it is not derived from Animal or Human sources.

1.1 Graphic Images

Figure 1 illustrates the Centrifugal Pump (CP) Safira Centriflux with BRCoating and the blood inlet and outlet connectors.

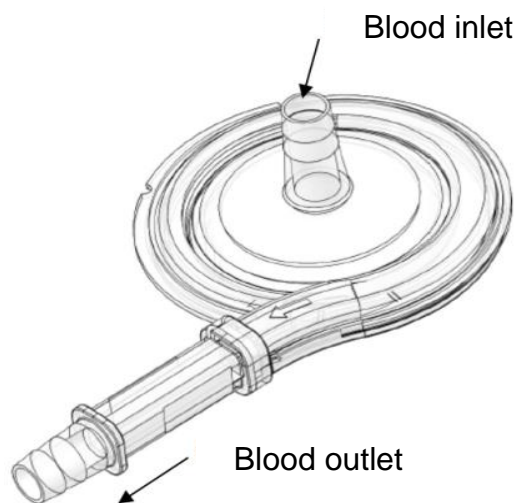

Figure 1 – Connectors of Centrifugal Pump Safira Centriflux with BRCoating.

Figure 2 illustrates the Centrifugal Pump Safira Centriflux with BRCoating and its components.

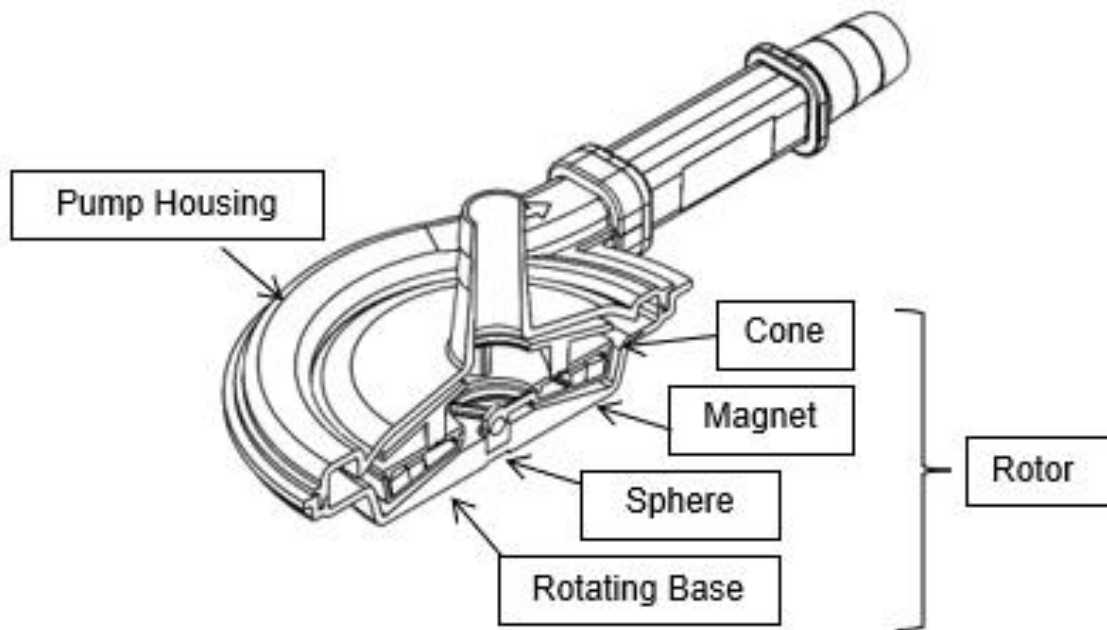

Figure 2 – Components of Centrifugal Pump Safira Centriflux with BRCoating.

1.2 Technical Specifications

The functions of each component of Centrifugal Pump Safira Centriflux are detailed in Table 1 and the raw materials that compose it are listed in Table 2.

Table 1 - Components of the Centrifugal Pump Safira Centriflux with BRCoating and their respective functions.

Pump Component	Function
Pump housing	Limits pump filling
Rotor	Generates flow
Inlet connector	Blood Input
Outlet connector	Blood output
Plugs	Protects connectors
BRCoating	Coating solution

Table 2 - Raw materials of the Centrifugal Pump Safira Centriflux with BRCoating.

Pump Parts	Raw Material
Pump Housing	Polycarbonate
Rotating Base	Polycarbonate
Magnet	Neodymium
Cone	Polycarbonate
Sphere	Safira Ruby
Inlet connector	Polycarbonate
Outlet connector	Polycarbonate
Plugs	Polyethylene
BRCoating	Polyethylene glycol
	Human Recombinant Albumin

The technical specification of the Centrifugal Pump Safira Centriflux with BRCoating can be found in Table 3.

Table 3 - Characteristics of the models of Centrifugal Pump Safira Centriflux with BRCoating.

Characteristics	
Blood flow rate	1 – 7 L/min
Maximum Operating Pressure	780mmHg
Maximum outlet Pressure	750mmHg
Internal Surface	192cm ²
Priming Volume	32 ml
Maximum pump speed	5000 rpm
Compatible Systems	RotaFlow RF-32 Bioconsole 540/550/560 with magnetic adapter* Centripump with magnetic adapter*
Connectors	
Blood inlet	3/8" (9.5 mm)
Blood outlet	3/8" (9.5 mm)
Materials	
Safira body	Polycarbonate
Rotor	Polycarbonate
Magnet	N48 Bipolar
Protective covers	Polyethylene
Coating	BRCoating

*609620 – Centrifugal Pump Safira Magnetic Adapter

Disclosable information: Information on blood cell damage, data tolerances and leaching. If during the use of this device or as a result of its use, a serious incident has occurred, please report it to the manufacturer and/or its authorized representative and to your national authority.

2 PRESENTATION

The Centrifugal Pump Safira Centriflux with BRCoating is sterile (sterilized by Ethylene Oxide - ETO) and non-pyrogenic. In its primary packaging, the product is packed in Tyvek paper envelope and polyethylene film, each envelope contains a product unit. In its secondary packaging, the Centrifugal Pump is packed in a cardboard box, containing a unit of the primary packaging. The instruction manual accompanies the product, in the secondary packaging.

3 INTENDED PURPOSE

The Centrifugal Pump Safira Centriflux with BRCoating is intended to be used as an extracorporeal blood pump for extracorporeal membrane oxygenation (ECMO) technique in extracorporeal life support (ECLS) procedure. Braile does not specify the maximum period of use of the Centrifugal Pump Safira Centriflux with BRCoating for this procedure, nor the ideal time to change it. The decision on whether to replace the product rests with the medical team.

The Centrifugal Pump Safira Centriflux with BRCoating is also intended to be used as an extracorporeal blood pump for use in cardiopulmonary bypass procedures for up to 6 hours.

4 INDICATION FOR USE

The Centrifugal Pump Safira Centriflux with BRCoating is indicated for the extracorporeal membrane oxygenation (ECMO) technique in the extracorporeal life support (ECLS) procedure in patients with cardiac and/or respiratory failure. The Centrifugal Pump Safira Centriflux with BRCoating is also indicated to be used for patients who need surgical procedures requiring cardiopulmonary bypass (CPB).

The Centrifugal Pump Safira Centriflux with BRCoating is for use with patients when required blood flow rate will not exceed 7L/min.

This device shall only be used by properly trained and qualified personnel.

5 CONTRAINDICATIONS

The Centrifugal Pump Safira Centriflux with BRCoating is contraindicated to perform functions other than blood pumping in perfusion circuits in cardiac surgery and in extracorporeal life support (ECLS), or when in the opinion of the medical team the use is contrary to the best benefits for the patient.

6 CLINICAL BENEFITS

Enabling extracorporeal life support (ECLS) procedure that require extra corporeal membrane oxygenation (ECMO) or surgical procedures that require cardiopulmonary bypass by using blood circuits including this device.

7 ADVERSE EFFECTS

Use of this medical device may cause: Pressure drop, Hemolysis, Blood Loss, Inflammatory reaction, Infection Organ and tissue failure; Septic Shock, Kidney Failure, Permanent damage; Death.

8 INSTRUCTION FOR USE

8.1 Circuit Assembly

- a. Open the sterile packaging using aseptic techniques.
- b. Remove the centrifugal pump and place it on its coupling in the device, using the blood outlet connector as a reference.
- c. Fit the pump into the housing's fixed lock, as shown in Figure 3, item 1.
- d. Pull the movable lock to release the pump fitting from the housing (Figure 3, item 2).
- e. Make sure the pump is properly fixed in the housing (Figure 3, item 3).
- f. Connect the PVC tubes checking the blood inlet and outlet connections.
- g. Remove the centrifugal pump from the device coupling and hang it up using the tubes.
- h. Position the device flow sensor in tube lines mounted after the Centrifugal Pump Safira Centriflux.

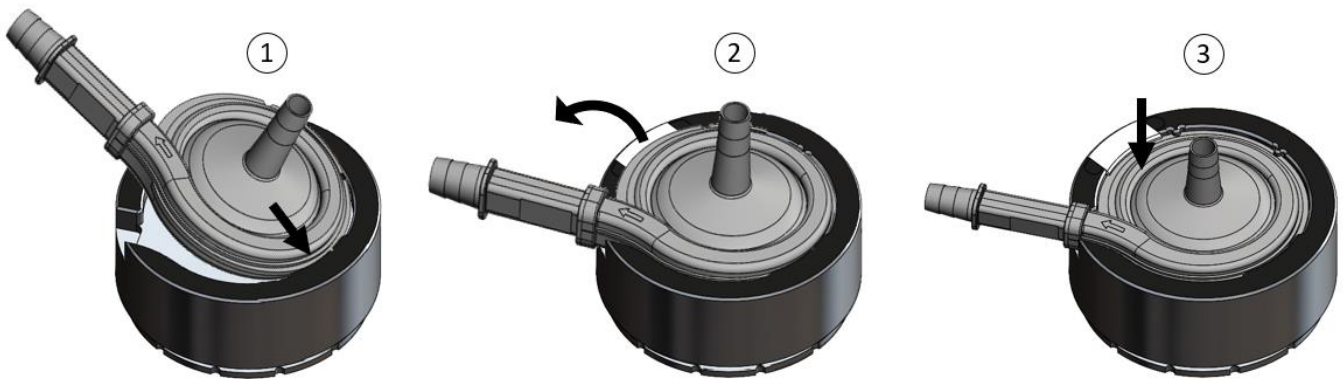

Figure 3 - Pump fitting

8.2 Filling with Prime for ECLS

- a. Allow serum to flow through serum line 1, filling the centrifugal pump and the oxygenator by gravity. Check that the oxygenator recirculation and bubble-trap lines are open.
- b. Once the centrifugal pump and oxygenator are filled, close the oxygenator recirculation and bubble-trap lines.
- c. Place the centrifugal pump on the ECMO device coupling and start rotation.
- d. Once the entire circuit is filled and free of bubbles, close serum lines 1 and 2 and remove the clamp between them.
- e. Stop console rotation and disconnect the serum lines from the prime connectors 1 and 2. Cap the luer with a sterile luer cover. Make sure there are no air bubbles in the body of the luer.
- f. Remove the MM extender from the stopcock of the bubble-trap connector and cap with a sterile luer cover.
- g. Keep a clamp on the arterial line and another on the venous line.
- h. Read the instructions on the manual for the Membrane Oxygenator Oxyprime ECMO with BRCoating and Tubing Set for ECMO with BRCoating for complete instruction on filling the circuit.

8.3 Filling with Prime for Cardiac Surgery

- a. Insert prime solution into the venous blood reservoir
- b. Slowly loosen the clamp from the inlet line so that the prime solution flows by gravity and fills the centrifugal pump, eliminating all air from the circuit.

- c. Gradually increase the device rotation speed and release the clamp from the pump outlet line; allow the solution to circulate and fill the line where the flow meter is positioned.
- d. Stop the rotation of the device and clamp the Pump inlet and outlet lines.
- e. To adjust the zero of the flow-meter, follow the directions on the device instruction manual.
- f. After adjusting the zero of the flow-meter, remove the clamp from the pump inlet line.
- g. Increase the machine rotation speed to 1700rpm and remove the clamp from the pump outlet line, and fill the entire ECC circuit.

8.4 Start of infusion

- a. Remove the clamps from the venous line.
- b. Increase the device rotation speed to 1700rpm.
- c. Remove the clamp from the arterial line simultaneously with the increase in rotation speed.
- d. Adjust the blood flow according to the patient's need.

8.5 Perfusion Control

- Regulate blood flow from the device rotation speed.
- Monitor variations in blood flow without changing the rotation speed. These may result from resistance in the circuit or in the patient.
- Make changes in the device rotation speed to correct flow variations due to line resistance.

8.6 End of Perfusion

- a. Decrease device rotation speed, and consequently blood flow.
- b. Clamp the arterial and venous lines, simultaneously.
- c. Close the gas flow.
- d. Stop device rotation.

8.7 Replacing the Centrifugal Pump

- a. Keep a spare centrifugal pump.
- b. Clamp the arterial and venous lines simultaneously.
- c. Stop device rotation.

- d. Place the tube clamp close to the blood inlet and outlet connectors.
- e. Remove the venous line from the blood inlet connector of the centrifugal pump and connect to the inlet on the new pump.
- f. While controlling the blood flow with clamps, fill the centrifugal pump, ensuring that there is no blood loss.
- g. Once the centrifugal pump is filled and free of air bubbles, connect the centrifuge line to the blood outlet connector of the new centrifugal pump.
- h. Start the device rotation and, if necessary, use the oxygenator bubble-trap outlet to remove air bubbles.
- i. Start the infusion according to the instructions for starting the infusion.

9 WARNINGS AND PRECAUTIONS

- Read the instructions before use.
- Single use product. Do not re-sterilize or reuse the product. There are no data to support sterility, pyrogenicity and functionality of devices after reprocessing.
- Reprocessing prohibited. Reprocessing may compromise the sterility, biocompatibility and functional integrity of the device (leaks and low performance);
- Do not use non-sterile products; they must be sterilized before use.
- Do not use the product after the expiry date.
- Do not use the product if it is damaged or the packaging is broken.
- Before use, the product must be checked for proper functioning and to ensure the model is suitable for its intended purpose.
- Product intended exclusively for medical use.
- The product should only be used by people specially trained on infusion techniques.
- The procedure and the correct application of the product are the responsibility of the doctor who performs the treatment.
- The product must not be used under conditions that contradict its technical specifications, under penalty of loss of performance or accidents. It is up to the person responsible for using the product to check in advance whether the technical specifications meet the needs of the procedure to be performed.
- Always use aseptic techniques when handling the product after opening.
- Avoid any impacts during transport or use.
- Do not use the product in case of doubt.

- After use, product and packaging disposal must comply with hospital and/or local government policy.
- Check the product carefully before use. The operation of the product packaging may be affected by transport. It is not possible to ensure full product operation when transport damage occurs. If the product has been dropped or crushed, it cannot be used and must be replaced with a new product.
- Always keep a spare unit of the product during the procedure.
- The manufacturer is not responsible for damage resulting from lack of experience, misuse or failure to follow the instructions for use.
- During the procedure, blood anticoagulation protocol should be adopted.
- Protamine should not be used in patients before or during extracorporeal circulation.
- It is necessary to provide the correct heparinization and accurate monitoring of the anticoagulation status before, during or after extracorporeal circulation.
- Check all circuit connections in advance to prevent any leaks.
- Remove all air from the extracorporeal circuit before the start of the infusion using the circuit prime procedure.
- It is recommended to start the procedure immediately after filling with prime in order to minimize the period of microbiological contamination, precipitation of the filling solution.
- Do not make changes to the product.
- Do not use the product if not all connectors are protected with a protective cover. The protective covers must be retained immediately before use.
- Regularly monitor the patient to identify side effects from extracorporeal circulation (e.g., infections, hemolysis, post-perfusion syndrome and organ damage).
- Regularly monitor the patient's clotting status (e.g., activated clotting time and partial thromboplastin time). The anticoagulation control protocol is the responsibility of the responsible user.
- Broken and/or leaking connectors must be replaced.
- Tube metal clamps should be available.
- Because it is an essentially mechanical device, in direct contact with blood, the centrifugal pump is potentially subject to loss of performance due to possible failures that may occur in any of its internal elements, as well as adverse effects from biocompatibility, common to any device of ECMO circuit, characterized by

hemolytic trauma, inflammatory reactions and thromboembolic phenomena, but not limited to these.

- In case of need to replace the product during the infusion procedure, proceed according to the Product Replacement Instructions.
- Do not use the pump if it has been dropped or showing crevices, cracks, leaks or any other non-conformities.
- The centrifugal pump must never be operated when empty, that is, without prime solution inside. This can damage your internal components.
- Whenever the Centrifugal Pump is stopped (zero flow), the gas flow must be closed (zero flow), under the risk of gas embolism.
- Do not use or store the Centrifugal Pump Safira Centriflux near to equipment or devices that may affect the magnetic field of the pump magnets or even be affected by them.
- The accidental entry of massive amount of air into the pump causes it to be depressed, resulting in loss of blood flow. In these cases, turn off the pump and remove the air to resume circulation.
- Braile Biomédica does not recommend using this product with equipment from other manufacturers, as it cannot guarantee compatibility between products and, consequently, their safety and effectiveness.
- Avoid retrograde flow and potential patient bleeding at the beginning of the infusion. Start the infusion at 1700rpm.
- Do not start rotation if the pump inlet line is clamped, this can generate a negative pressure with consequent formation of air bubbles.
- The flow generated by the centrifugal pump can vary during operation, even if the rotation speed remains unchanged. This can occur due to possible variations in the circuit resistance (such as clamped or kinked tubes) or in the patient's resistance (such as vasoconstriction and vasodilation). Monitoring of the actual flow at the pump outlet is required to detect variations and flow corrections, if necessary, through machine rotation speed.
- Before use, the product must be checked for correct operation and to ensure the model is suitable for its intended purpose. Check that the holes are not closed.
- The product should be used immediately after opening the package. After use, dispose of safely as medical waste according to health institution policies. The product is biohazardous as it is contaminated with blood;

10 STORAGE AND TRANSPORT

The product, in its original packaging, must be stored in a clean, dry, weather-free environment and at temperatures above -10°C and below 40°C.

For its transportation, it should never be refrigerated, frozen or exposed to temperatures above 45°C.

11 PRODUCT DISPOSAL

After use, follow the **safe disposal procedure, item 11.1**, to safely dispose of the device. Product and packaging disposal must comply with the hospital and / or local government policy. The product must be disposed of only in hospital / infectious waste. The product is biohazardous as it is contaminated with blood.

11.1 Safe Disposal Procedure

Warning: Wear gloves to carry out this process, there is a risk of contamination.

Note 1: It is not necessary to disconnect the bloodlines tubes.

Note 2: This safe disposal procedure serves the cardiopulmonary bypass circuit and its main components (Tubing Set, Oxygenator, Blood Reservoir Venous/Cardiotomy and centrifugal pump). For specific components, follow instructions that come with the device in question.

- a. Remove the aspirators lines from the roller of the heart-lung machine and set them aside on a secure surface.
- b. Detach the centrifugal pump and set aside on a secure surface.
- c. Position a surgical field below the oxygenator to avoid wetting the floor, clamp the water lines near the oxygenator's water inlet/outlet connectors, and, disconnect the lines, set the pipes aside on a safe surface.

Note 3: For the next steps, use the disposal waste for contaminated products.

Note 4: Always handle the Venous Reservoir and the Cardiotomy Reservoir in an upright position to avoid blood overflow through the top cover.

- d. Remove the oxygenator and venous reservoir from their respective holders and discard it carefully.
- e. Remove the Cardiotomy reservoir from the holder and discard it carefully.
- f. Discard the centrifugal pump and the pump line carefully.
- g. Discard the remaining lines.

12 PERFORMANCE DATA

Note1: The actual obtainable flow is dependent on afterload of the pump which results from the extracorporeal circuit components and the patient's arterial resistance.

Note2: ΔP (Pressure drop) is the difference between the outlet of the pump and the inlet of the pump.

The performance of Centrifugal pump Safira Centrflux with BRCoating can be seen in Figure 4.

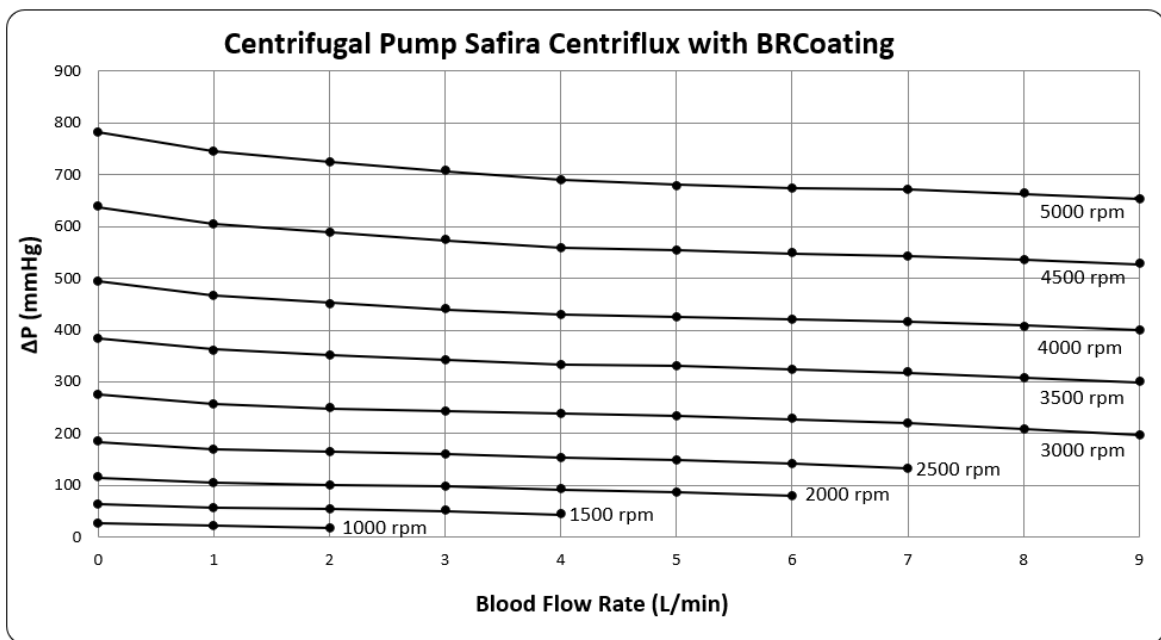

Figure 4 - Performance (ΔP vs Flow rate)

13 SHELF-LIFE

The Centrifugal Pump Safira Centrflux with BRCoating is valid for 3 years after the sterilization date, considered sterile only if the package has not been violated. Check the validity date on the label of the product package.

14 WARRANTY

Braile Biomédica Indústria, Comércio e Representações Ltda, certifies that the product has been manufactured with due care, with good quality materials, and is warranted for manufacturing defects pursuant to the Brazilian Consumer Protection Code. It further clarifies that if the product is violated by unauthorized or unqualified personnel, the warranty will be void. The manufacturer states that any other warranty expressly or implicitly granted by others shall not be valid. The use of the product is restricted to doctors or qualified and

trained technicians under the supervision of the responsible physician, who are familiar with the procedures for using the product, being their responsibility said use. The manufacturer will not be responsible for any damage resulting from product misuse.

Braile Biomédica Ltda also states that the right to complain about the product will be governed by the provisions contained in Article 26 of the Brazilian Consumer Protection Code (Law 8.078 / 90). No agent, employee, representative, or distributor of the Braile Biomédica Ltda has the authority to change or amend what is described herein, assume or bind the Braile Biomédica Ltda to any other liability or warranty in connection with this product.

This product was developed and manufactured based on legal and regulatory requirements, and under strict quality control, aiming at managing potential risks of its use, in order to minimize them within safe limits. However, Braile Biomédica cannot ensure that the product is totally free from the likelihood of failure, so that its use must respect all precautions, restrictions, warnings, special care and relative instructions for use, as well as must be constantly and carefully monitored.

15 MANUFACTOR INFORMATION

Manufactured by:

Braile Biomédica Indústria Comércio e Representações Ltda

CNPJ N°: 52.828.936/0001-09

Av. Presidente Juscelino Kubitschek de Oliveira, 1505 – Jardim Tarraf I

CEP: 15091-450

São José do Rio Preto – São Paulo

Imported and distributed by:

Mars Medical























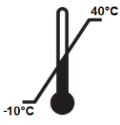

Landhausstrasse 46

70190, Stuttgart – Germany

Tel: +49 1751938653

E-Mail: info@marsmedical.de

16 SYMBOLS DESCRIPTION

	Manufacturer		Use-by date
	Catalog Number		Sterile
	Serial Number		Sterilized using ethylene oxide
	Batch Code		Do not use if packaging is damaged
	Date/ Country Manufacture		Fragile, handle with care
	Non-pyrogenic		This way up
	Consult Instructions for Use or electronic instructions for use		Stacking limit
	Temperature limit		Recyclable
	Keep dry		Medical Device
	Keep away from sunlight		Do not re-use
	Unique Device Identifier		Do not re-sterilize
	CE Mark		Authorized representative in the European Union

17 LABEL TEMPLATE



Braile Biomédica Indústria Comércio e Representações Ltda.
 Av. Presidente Juscelino Kubitschek de Oliveira, 1505 - Jardim Tarraf I
 CEP 15091-450 - São José do Rio Preto - SP - Brasil
 Fone: +55 17 2136-7000 SAC: 0800 707 20 50
 CNPJ: 52.828.936/0001-09 www.braile.com.br



Mars Medical
 Landhausstrasse 46
 70190, Stuttgart – Germany
 Tel: +49 1751938653
 E-Mail: info@marsmedical.de

EC REP

CENTRIFUGAL PUMP SAFIRA CENTRIFLUX WITH BRCOATING

Description (Model): 616322

Package Content: 01 unit of Centrifugal Pump Safira Centriflux with BRCoating / 01 Instruction for Use
 Contains 1 unit destined to medical application

ANVISA Registration nº: XXXXX
Technical Name: Centrifugal Pump CPB
Technician in Charge: Vladimir D. A. Ramirez – CRF-SP 09010

Read instructions before use
 Single use product / Prohibited reprocessing

Indications, Precautions, Warnings, Instructions of Use, Preservation Cares*.
 * Please refer to leaflet insert "INSTRUCTIONS OF USE".

REF XXXXXX **SN** XXXXXX **LOT** XXXXXX

YYYYY/MM/DD

UDI

YYYYY/MM/DD

STERILE

STERILE EO

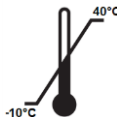

MD

braile.com.br/en/
 produtos/cemark
 products

The external package has the following informations

The product must be stored and transported in its original packaging, in a clean, dry, weather-free environment and at a controlled temperature.

